

広帯域型AEセンサ

Wide bandwidth AE sensors

S型 (シングルエンド)

S type (Single-end)

型式 Model	周波数範囲 kHz Frequency Range	感度※ dB(0dB=1V/m/s) Sensitivity	使用温度範囲 ℃ Temperature Range	形状 mm Size	質量 gm Weight	オプションホルダー Optional holders (P.44)
1045S	200~1,300(±6dB)	53±3	-20~+80	φ20×20H	30	① ⑤ ⑧ ⑨
2045S	300~2,200(±6dB)	49±3	-20~+80	φ20×20H	30	① ⑤ ⑧ ⑨
5045S	500~4,000(±10dB)	44±3	-20~+80	φ20×20H	30	① ⑤ ⑧ ⑨

※ローノイズケーブル0.5m(45pF)を含んだ値 Value includes capacitance of low-noise cable 0.5m (45pF)

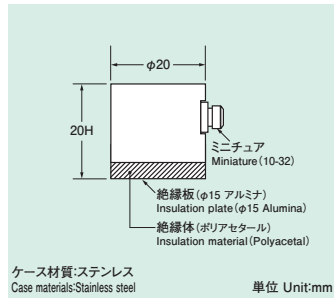

別売専用ケーブル Optional cable

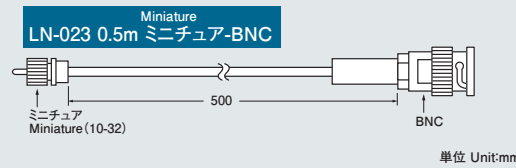

※MW型、REF型も用意しています。
Note:Type MW and type REF are also available.



1045S

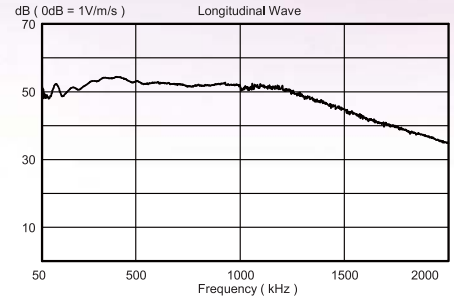

2045S

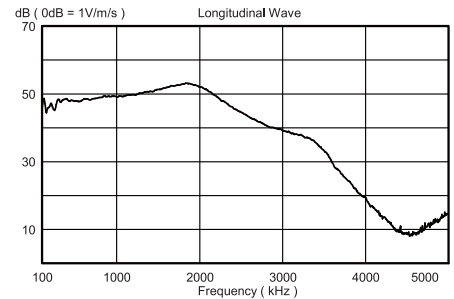

5045S

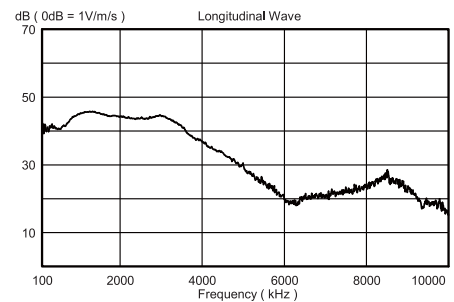

D型 (ディファレンシャル)

D type (Differential)

型式 Model	周波数範囲 kHz Frequency Range	感度※ dB(0dB=1V/m/s) Sensitivity	使用温度範囲 ℃ Temperature Range	形状 mm Size	質量 gm Weight	オプションホルダー Optional holders (P.44)
1045D	200~1,300(±6dB)	55±3	-20~+80	φ20×23H	44	① ⑤ ⑧ ⑨
2045D	300~2,200(±6dB)	51±3	-20~+80	φ20×23H	44	① ⑤ ⑧ ⑨

※ローノイズケーブル0.5m(45pF)を含んだ値 Value includes capacitance of low-noise cable 0.5m (45pF)

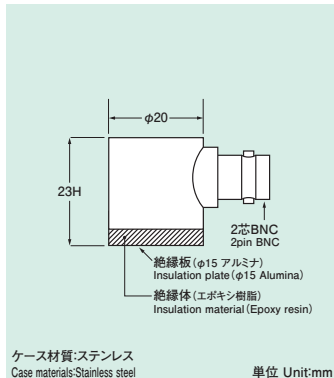

別売専用ケーブル(使用アンプに合わせて選択)

Optional cables (Choose a cable adapted to the amplifier installed.)

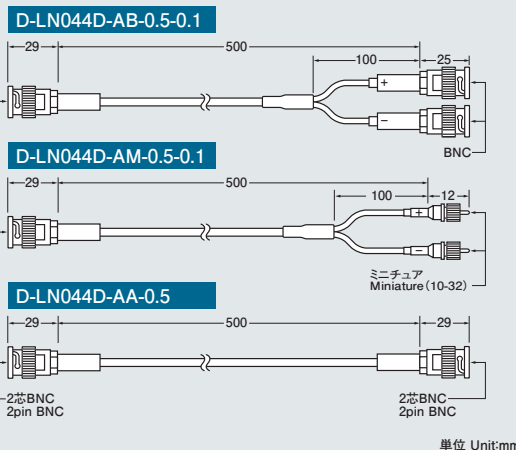

1045D

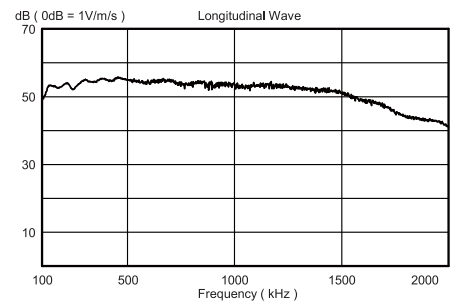

2045D

