

# 特殊センサ

## Special sensors

[ ACCELEROMETERS ]

弊社では特徴的な新製品の開発を行う一方、お客様のご要望に応じた特注品も承っております。

While developing new models of products with special characteristics, we are ready to receive any orders for models that meet your specific requirements.

### 複合センサ Dual output sensors

#### ● 振動・温度センサ

Vibration & Temperature sensor

#### TSAF51A

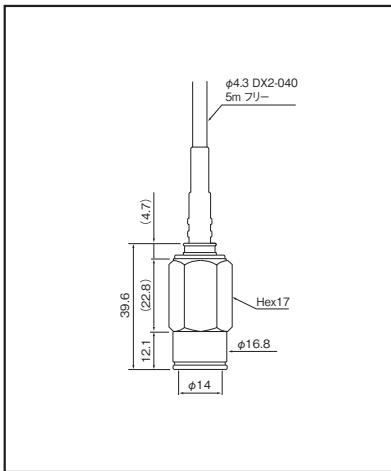

5mV/m/s<sup>2</sup>, ~8kHz

温度センサ内蔵

Built-in temperature sensor

アンプ内蔵防水絶縁

Built-in amplifier, case insulated, water-proof

#### ● 振動・AEセンサ

Complex sensor for Vibration and Acoustic emission

#### HS-10A-10M2

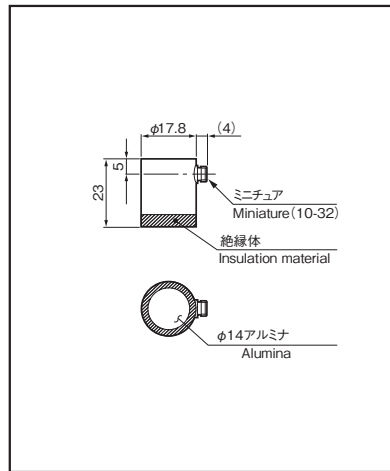

(Vib) 2mV/m/s<sup>2</sup>, ~20kHz

(AE) 63dB, 200~600kHz

アンプ内蔵

Built-in amplifier

#### ● インピーダンスヘッド (振動・フォースセンサ)

Impedance head (Vibration & Force sensor)

#### PFT215S

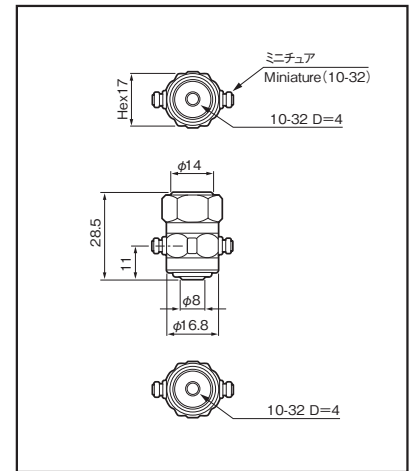

(Vib) 2pC/m/s<sup>2</sup>

(Force) 270pC/N

### 特定用途向けセンサ Specific use sensors

#### ● 校正用基準センサ

Reference accelerometer for calibration

#### REF-A3S-M6

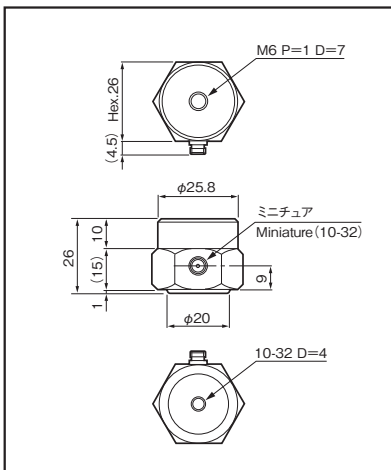

加振器取り付け用

Back to back type

0.4mV/m/s<sup>2</sup>, ~20kHz

#### ● 漏水センサ

Water leak detector

#### ABS-7000

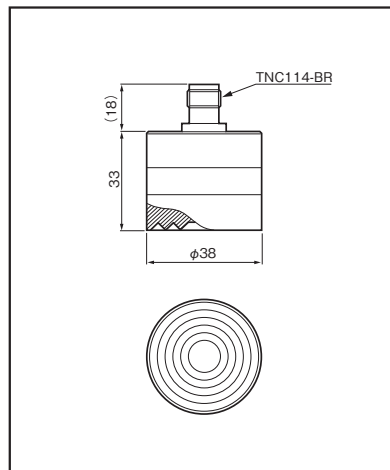

水道管からの漏水音の聴音用

Listening to leaks from water supply pipe

750mV/m/s<sup>2</sup>, 共振1kHz

#### ● センサデバイス

Sensor device

#### B52XM

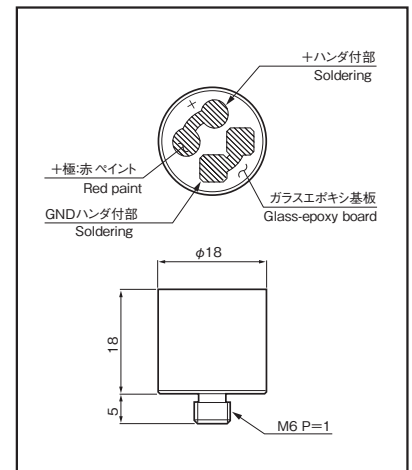

検出部単品

Detective component

50pC/m/s<sup>2</sup>, ~800Hz