

# AE传感器

## 工业用的AE传感器

型号	频率 kHz	灵敏度 ※ dB(0dB=1V/m/s)	使用温度范围 ℃	特点	质量 ※1 gm	任选夹具
1045SWA	200 ~ 1,300±10dB	73±5	-20 ~ +80	内置放大器, 防水 (IPX7) 绝缘	65	⑤ ⑧
1045SWH	250 ~ 1,000±6dB	56±3	-20 ~ +200	耐压防水 (IPX8), 高温型	50	⑨ ⑩
AE204SW	200±20%	66±3	-20 ~ +80	防水 (IPX7) 绝缘	41	① ⑥ ⑨ ⑩
AE204SH150-BNC	200±20%	(71±3)	-20 ~ +150	高温型	-	⑨ ⑩
AE204DH	200±20%	71±3	-20 ~ +200	高温型	25	⑨ ⑩
AE154DL	150±20%	68±3	-196 ~ +80	低温型 非绝缘	30	-

※ 1: 它不包括电缆

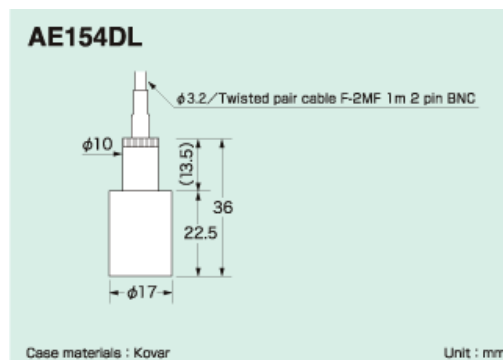
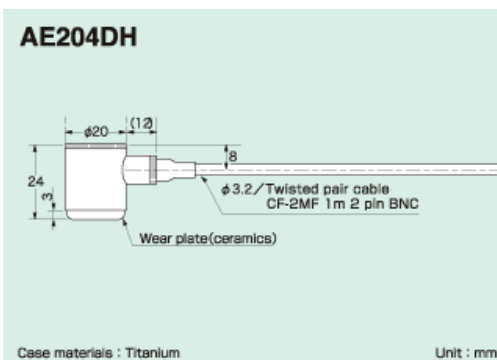
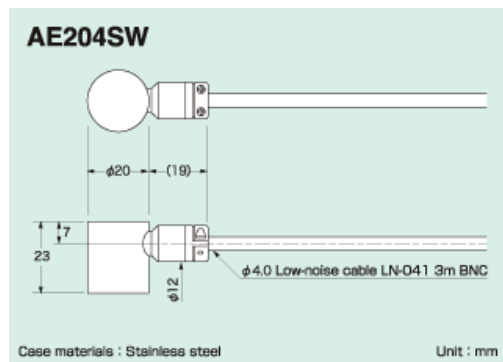
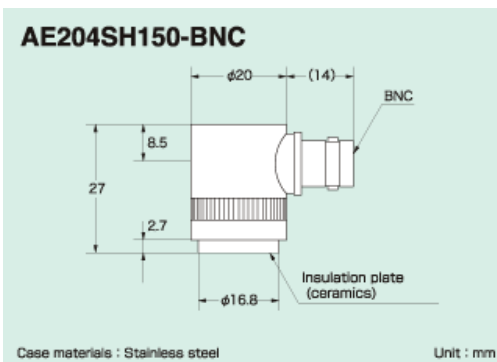
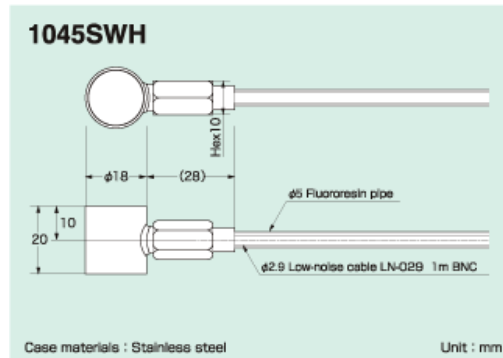
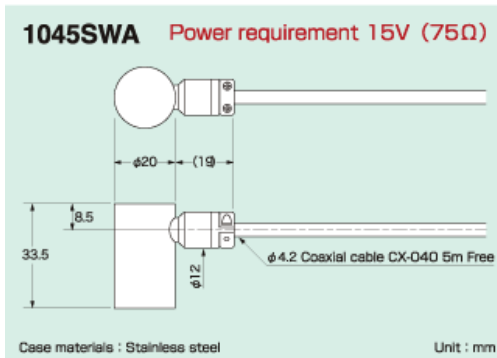

### 1045SWA

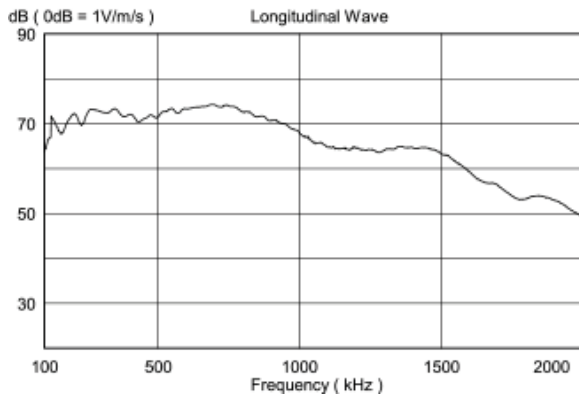

### 1045SWH

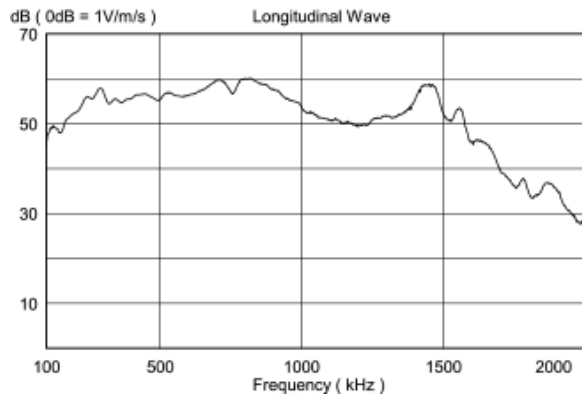

### AE204SW

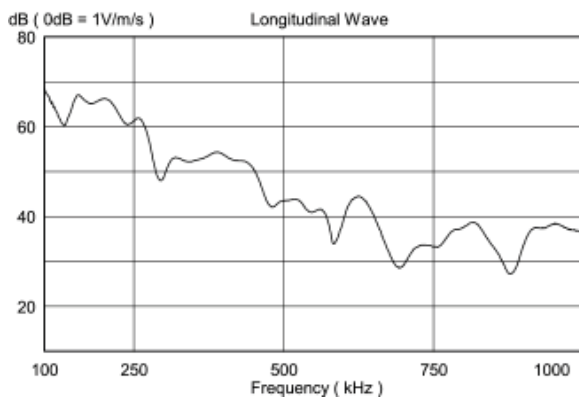

### AE204DH

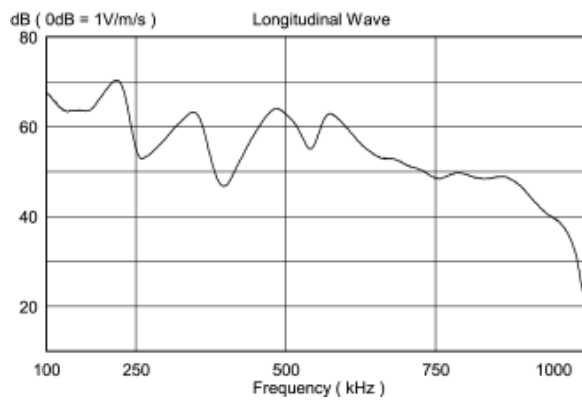

### AE154DL

