

アンプ内蔵型AEセンサ、その他

Built-in preamplifier AE sensors and others

アンプ内蔵型

Amplifier built-in type

| 型式 Model | 共振周波数 kHz Resonant Frequency | 感度 dB (0dB=1V/m/s) Sensitivity | 使用温度範囲 ℃ Temperature Range | 構造 Structure | 質量 gm Weight | 駆動電源 Power requirement |
|---------------------------------|------------------------------------|--------------------------------------|----------------------------------|-------------------|--------------------|---------------------------|
| AE303SA40-BNC-MH ^(※) | 30±20% | 120±3 | -20～+80 | 取付面絶縁 Isolated | 157 | 28V, 50Ω |
| AE503SA40-BNC | 50±20% | 122±3 | -20～+80 | 取付面絶縁 Isolated | 67 | 28V, 50Ω |
| AE144SA40-BNC | 140±20% | 117±3 | -20～+80 | 取付面絶縁 Isolated | 56 | 28V, 50Ω |
| AE304SA40-BNC | 300±20% | 111±3 | -20～+80 | 取付面絶縁 Isolated | 61 | 28V, 50Ω |

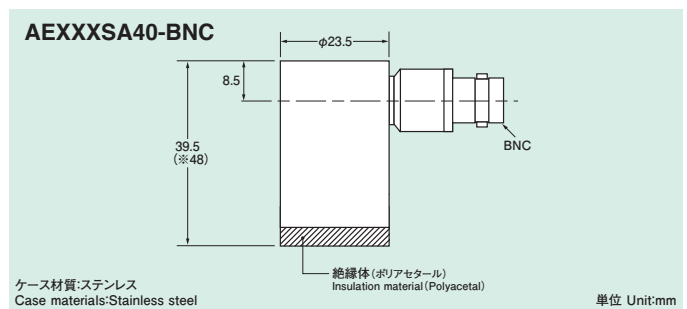

AE303SA40-BNC-MH

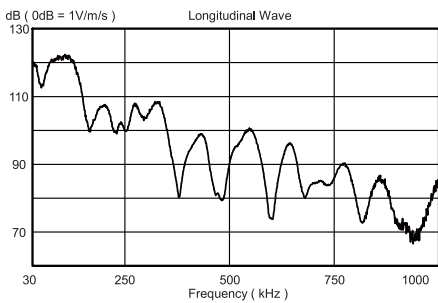

AE144SA40-BNC

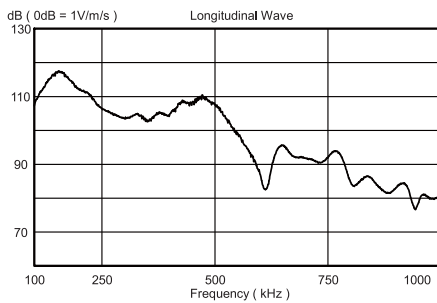

AE304SA40-BNC

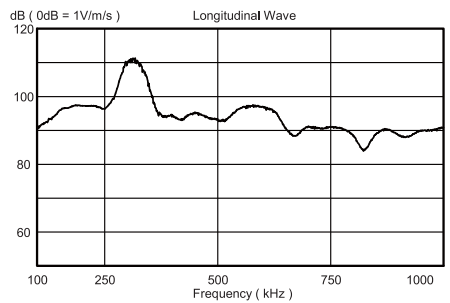

リファレンス用

Reference use

| 型式 Model | 周波数範囲 kHz Frequency Range | 感度 dB (0dB=1V/m/s) Sensitivity | 使用温度範囲 ℃ Temperature Range | 特徴 Features | 質量 gm Weight |
|-------------|---------------------------------|--------------------------------------|----------------------------------|--|--------------------|
| REF-VL | 50～600±6dB | 54±3 (※1) | -20～+80 | 低周波広域帯 Low-frequency wide bandwidth | 450 |
| REF10M | ～10MHz | 30±5 (※2) | -20～+80 | 広域帯 Wide bandwidth | 155 |

※1: ローノイズケーブル1m (90pF) を含んだ値
Value includes capacitance of low-noise cable 1m (90pF) "LN-023 1m Miniature-BNC"

※2: ローノイズケーブル0.5m (45pF) を含んだ値
Value includes capacitance of low-noise cable 0.5m (45pF) "LN-023 0.5m BNC-BNC"

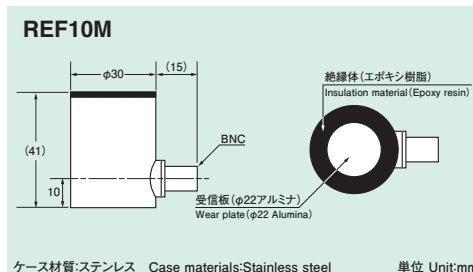
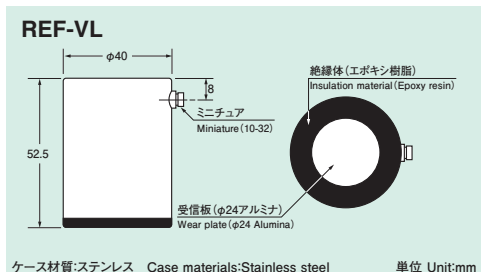

REF-VL

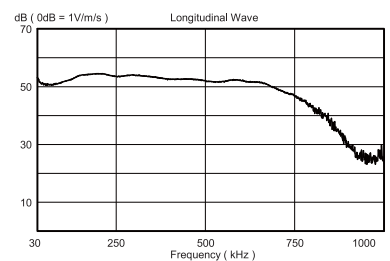

REF10M

